

REV	E.C.N NO.	CONTENT	CHK	DATE
V1.0		ORIGINAL	ZX	2024.07.24

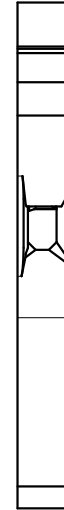
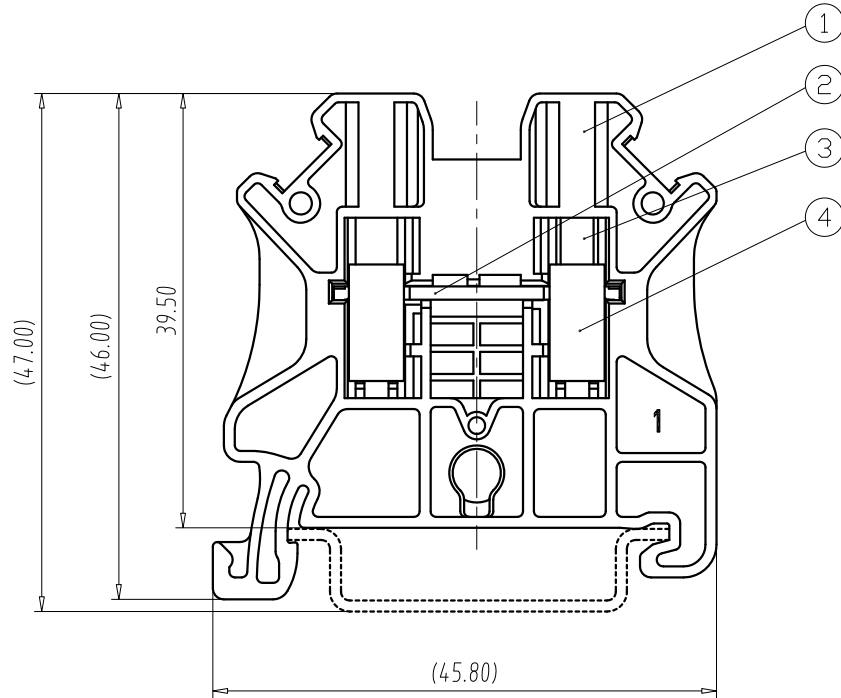
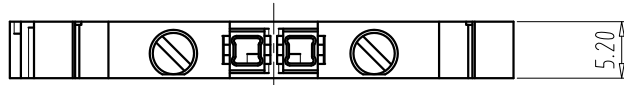

NOTES:

- IEC:
 - Rating:1000V, 24A;
 - Rate Impulse Voltage:8000V;
 - Insulation Resistance:500MΩ or more at DC5000V;
 - Contact Resistance: ≤5mΩ
 - Material Group: I;
 - Pollution Degree:3;
 - Overvoltage Category:III;
 - Suitable Electric Wire:0. 2mm²~2. 5mm² & 4mm² (SOL)
- UL:
 - Rating:600V, 20A;
 - Insulation Withstands Voltage:AC2200V/MIN;
 - Suitable Electric Wire:26AWG~12AWG
- Using Temperature Range:-40°C~+115°C;
- Screw Torque Value:0. 5N · m
- Strip length:9mm
- RoHS compliance;

TK2.5(X S)

- Slot screw
- Color:
 - M19:Grey
 - L01:Blue
 - R03:Red
 - K:Black
 - ⋮

ITEM	NAME OF PART	Q'TY	MATERIAL	NOTE
4	BLOCK	2	Copper Alloy	M3/Ni Plated
3	SCREW	2	STEEL	M3/Zn Plated
2	CURRENT CARRIER	1	Copper Alloy	Tin Plated
1	HOUSING	1	PA66	UL94 V-0

Total Pitch Tolerances in mm										Nominal dimension range in mm									
over	over	over	over	over	over	over	over	over	over	over	over	over	over	over	over	over	over	over	over
0	30	53	70	90	115	150	200	250	300	0	30	53	70	90	115	150	200	250	320
to	to	to	to	to	to	to	to	to	to	to	to	to	to	to	to	to	to	to	to
30	53	70	90	115	150	200	250	320		30	53	70	90	115	150	200	250	320	
±0.20	±0.25	±0.3	±0.35	±0.44	±0.55	±0.70	±0.85	±1.00	±0.25	±0.30	±0.35	±0.44	±0.55	±0.70	±0.80	±0.90	±1.20		

DWG.	ZY	DATE	2020.07.01	UNITS	MM	SHEET/OF	1/1
CHK.		DATE		SCALE	15 : 1	A4	
APP.		DATE		NAME	TK2.5(XS)		
				DWGNO.	TLDW-TK25XS		

