

REV	E.C.N NO.	CONTENT	CHK	DATE
V0.0		ORIGINAL	ZHT	2021.03.22

- NOTES:**
- UL:
Rating:300V, 40A
Insulation Withstands Voltage:AC1600V/MIN
Suitable Electric Wire:24AWG~8AWG
 - IEC:
Rating:1000V(01P), 630V(≥02P), 41A
Rate Impulse Voltage:8000V(01P), 6000V(≥02P)
Insulation Resistance:500MΩ or more at DC500V
Contact Resistance:≤5mΩ
Material Group: I, Pollution Degree:2
Overvoltage Category:III
Suitable Electric Wire:0.2~6mm²,10mm²(SOL)
 - Using Temperature Range:-40℃~+105℃
 - Strip length:15mm
 - RoHS compliance

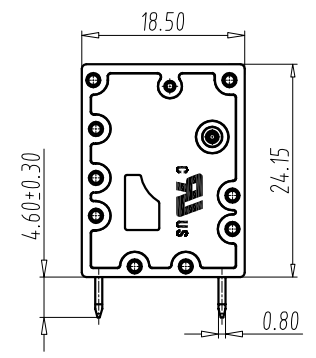
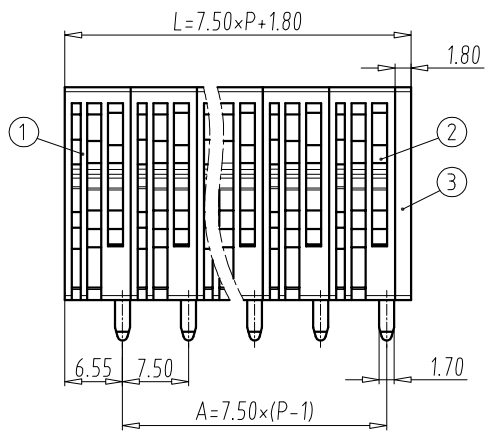
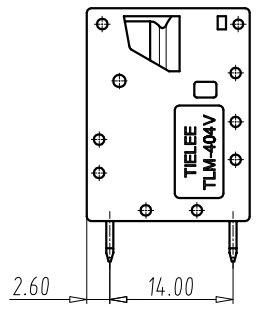
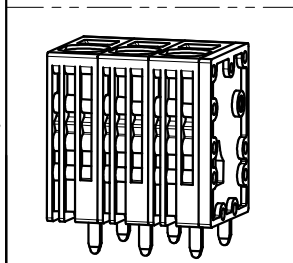

DIM	P	01	02	03	04	05	06	07	08
L		9.30	16.80	24.30	31.80	39.30	46.80	54.30	61.80
A		/	7.50	15.00	22.50	30.00	37.50	45.00	52.50
DIM	P	09	10	11	12	13	14	15	16
L		69.30	76.80	84.30	91.80	99.30	114.3	121.8	129.3
A		60.00	67.50	75.00	82.50	90.00	105.0	112.5	120.0

Total Pitch Tolerances in mm								Nominal dimension range in mm							
over	over	over	over	over	over	over	over	over	over	over	over	over	over	over	over
0	30	53	70	90	115	150	200	0	30	53	70	90	115	150	200
to	to	to	to	to	to	to	to	to	to	to	to	to	to	to	to
30	53	70	90	115	150	200	320	30	53	70	90	115	150	200	250
±0.20	±0.25	±0.3	±0.35	±0.44	±0.55	±0.70	±1.00	±0.25	±0.30	±0.35	±0.44	±0.55	±0.70	±0.80	±1.20

5	SPRING COIL	P	STAINLESS STEEL	/
4	SOLDER PIN	P	COPPER ALLOY	Sn Plated
3	COVER	1	PA66	UL94V-0
2	HOUSING-2	P-1	PA66	UL94V-0
1	HOUSING-1	1	PA66	UL94V-0
ITEM	NAME OF PART	Q'TY	MATERIAL	NOTE

DWG.	ZHT	DATE	2021.03.22	UNITS	MM	SHEET/OF	1/1
CHK.		DATE		SCALE	125 : 1	A4	
APP.		DATE		NAME	TLM-404V-XXP-X		
 ELECTRICAL MACHINERY(NINGBO)CO.,LTD.				DWGNO	TLDW-TLM404VXXPX		